

LASERLINE® global gas solutions.

Gas supply equipment for laser gas installations.

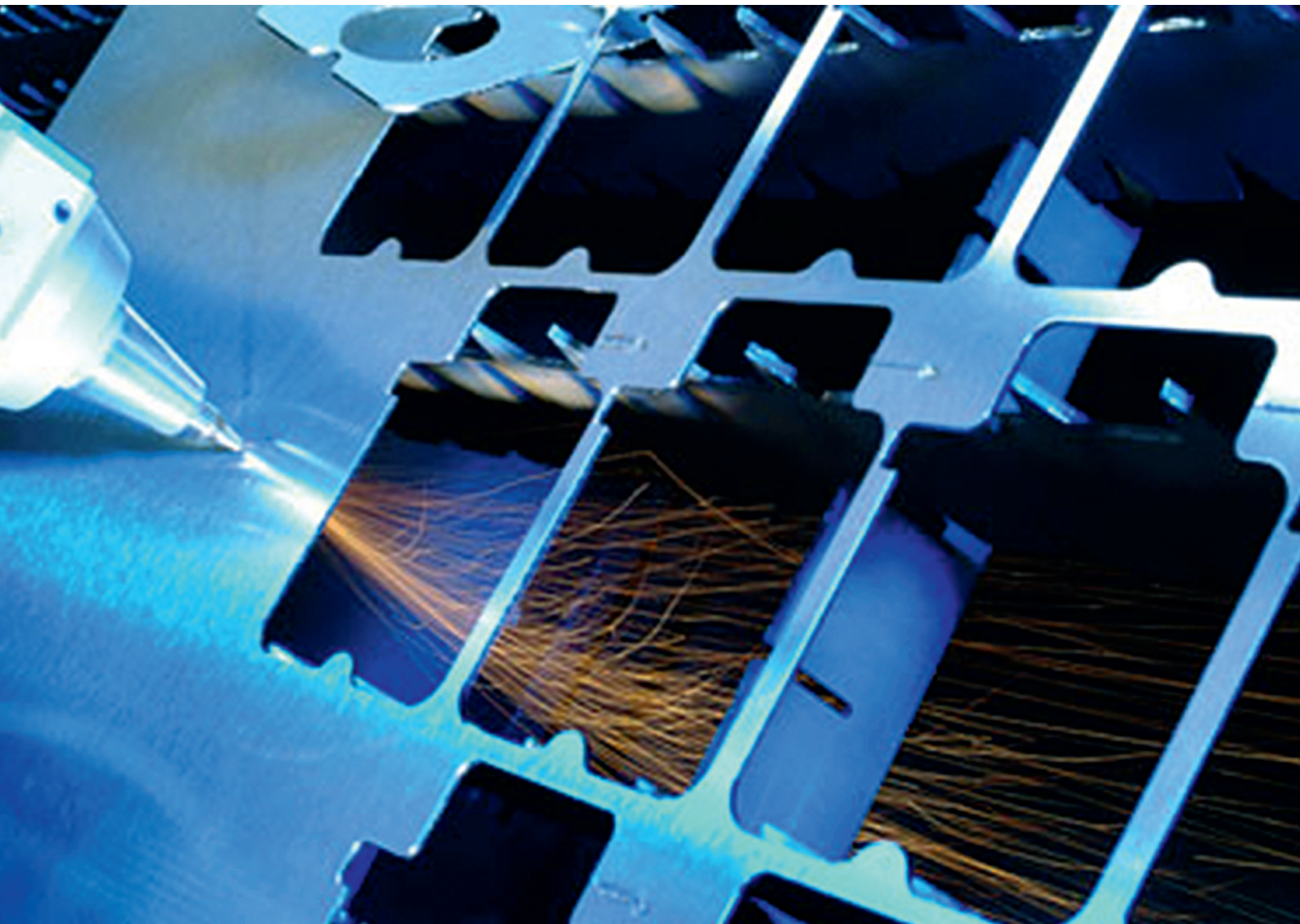

Total gas supply solutions.

This catalogue deals with products marketed as AGA's regional line of products for materials processing with laser within the manufacturing industry.

The hardware products comply with the relevant requirements, which apply to pressurized equipment, and should be installed in accordance with the regulations that apply to gas supply systems.

Contact AGA for information about regulations, design and correct

installation of gas supply systems. Also, periodical service of gas supply systems are conducted by AGA.

We reserve the right to change the appearance, shape and function of the products in keeping up to date with product development and regulatory requirements.



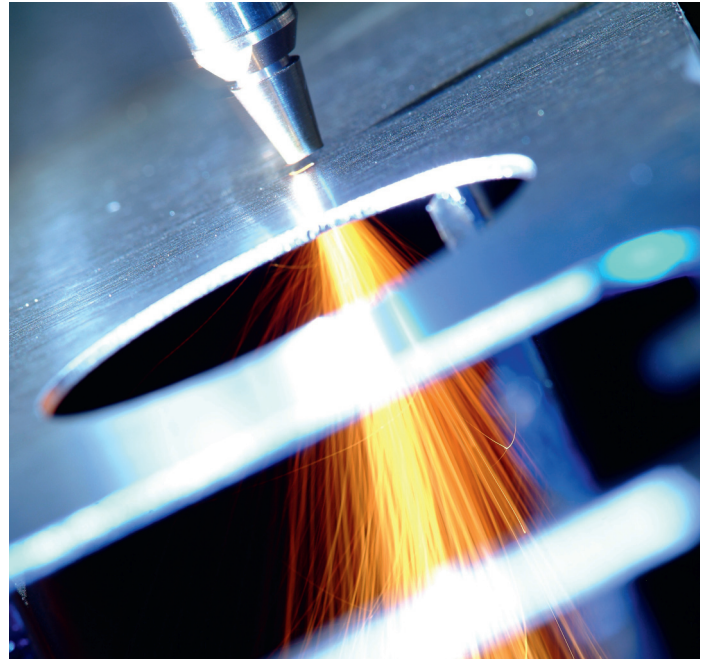

Gas supply systems for laser processing.

A gas supply system for laser gases consists of

- Gas supply, in normal cases from manifolds or tanks
- Pipelines
- Tapping points

Process gases

Process gases are used in welding or cutting processes. The most common gases are nitrogen, oxygen, helium and argon.

Resonator gases

These gases are used for creating laser light in CO² lasers. Resonator gases are used either as pure gases for mixing in the resonator, or as a premixed gas. There are a variety of different gas mixtures for lasers.

Tank

A cryogenic tank is used for larger consumption of process gases. The system consists of a super isolated tank and an evaporator. The evaporator transforms the gas from liquid to gaseous phase. The size of the tank system is chosen according to the actual gas consumption.

Manifolds

The manifolds are normally located in a separate tempered storage - placed outside the workshop. A manifold system consists of all necessary equipment to connect the cylinder or the bundle to the system, and supplies the pipelines with gas at a given flow and pressure. The capacity of the manifold is decided on basis of the maximum consumption. Delivery options and safety requirements must also be taken into consideration when designing a manifold system.

Pipelines

The piping is the actual supply network, and is combined with the necessary valves, safety valves and other equipment.

Tapping point

A central gas supply system includes one or more tapping points. These tapping points consist of valves and regulators. The laser machine is connected to the tapping point with hoses or pipelines to ensure that the relevant pressure and gas flow is fed into the laser. The actual pressure and flow may vary depending on the type of machine.

Standard packages for gas supply.

Solutions for gas supply

There are different levels of solutions for the gas supply system depending on service level, application and the consumption of gas. In reality there are 4 different categories when designing a gas system.

Basic

Cylinder regulator mounted directly on the cylinder and placed nearby the laser machine. This solution is suitable only for small gas consumption.

Standard

A wall mounted gas supply solution for one cylinder or bundle placed outside workshop and fixed tubing to the tapping point near by the laser machine.

Premium

A wall mounted gas supply solution placed outside workshop for one cylinder or bundle in operation and one cylinder or bundle in reserve. Fixed tubing to the tapping point near by the laser machine.

Ultra

A cryogenic tank with liquified gas and evaporator placed outside the building.

The choice of different solutions are illustrated below:

Typical types of delivery for the various applications

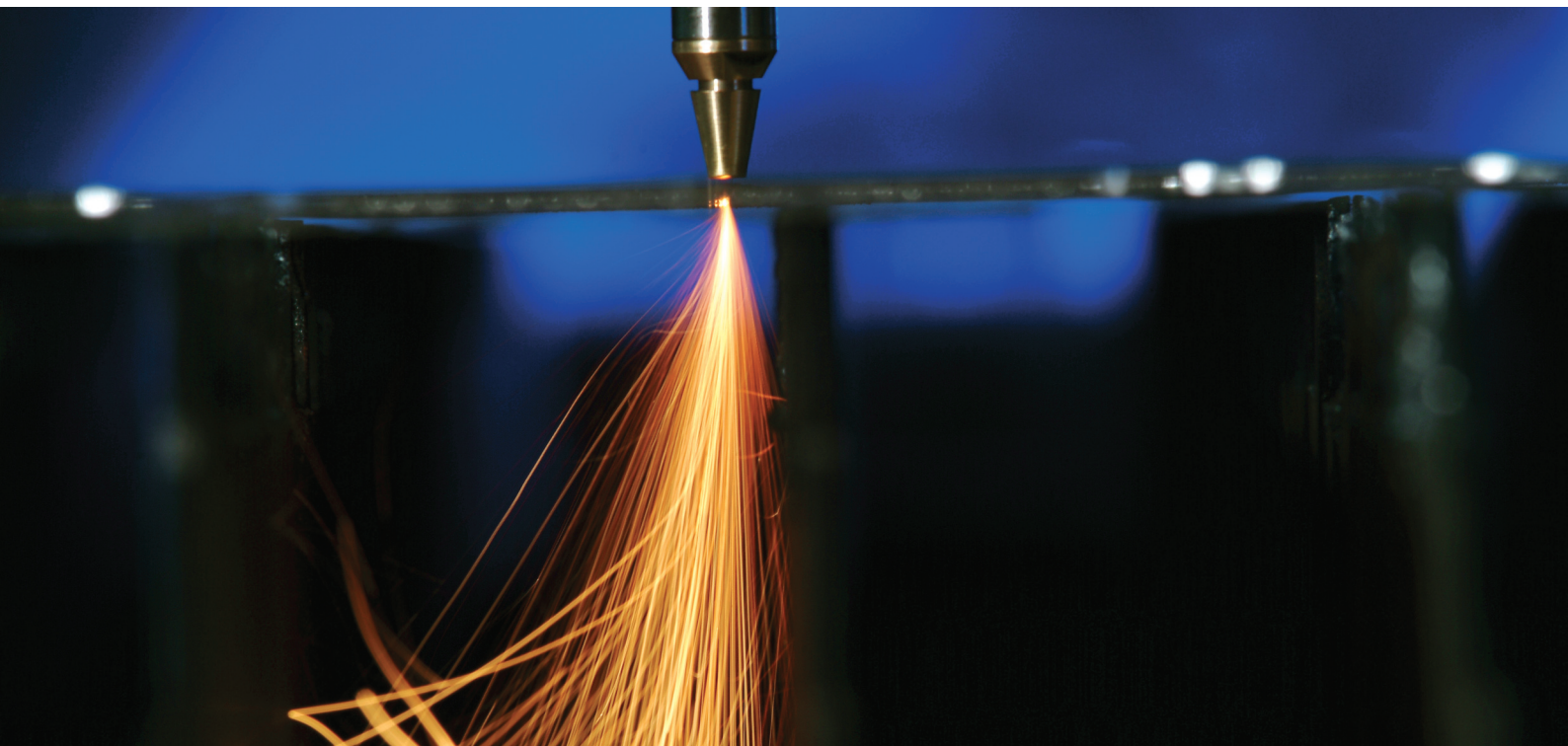
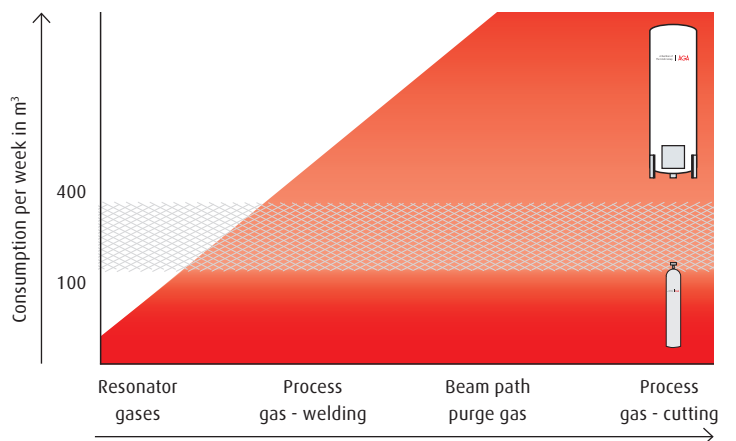

A35/A28.

Semi – automatic Manifold for bundles.

Application

Supply of process gases for laser cutting at high pressure and high flow rates. The manifold ensures continuous gas supply with no interruption when exchanging bundles. Two sets of bundles are connected to the valve unit. One bundle works as operational side, while the other is held in reserve. The changeover from empty to full bundle is done automatically. The standard version of the manifold is designed for one bundle in operation and one in reserve.

The manifold is equipped with self – purging valves on the high pressure side. These valves ensure the gas quality after changing of bundles. The high pressure in the hoses demands depressurization when changing the bundle.

Specification

- Double – sided pressure control panel with automatic changeover function.
- Purge valves on the inlet side with indicator.
- High pressure hoses between panel and bundles.
- Inlet pressure – 200 bars cylinder pressure.
- Outlet pressure – nitrogen: Factory set at approximately 42 bar on the operational side and 38 bar on the reserve side. Outlet pressure – oxygen: Factory set at approximately 30 bar on operational side and 26 bar on reserve side.
- Relief valves on regulators with G 3/8" ext RH.
- 18mm compression fittings in stainless steel on outlet.
- Inlet purge valves – W 21,8 x 1/14" ext. RH.
- Temperature range - 30 °C up to + 60 °C.
- Leak rate < 10-3 mbar l/s He.
- Mounting plate – Stainless steel.
- Weight regulator unit – 12,5 kg.
- Alternative model including contact gauges.



Capacity curve - Nitrogen

— $P_1 = 40$ (Inlet pressure $P_1 = \text{bar}$) — Max gas flow

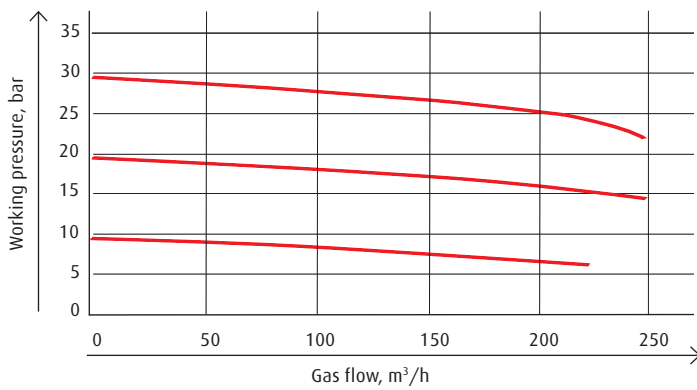

A35/A28.

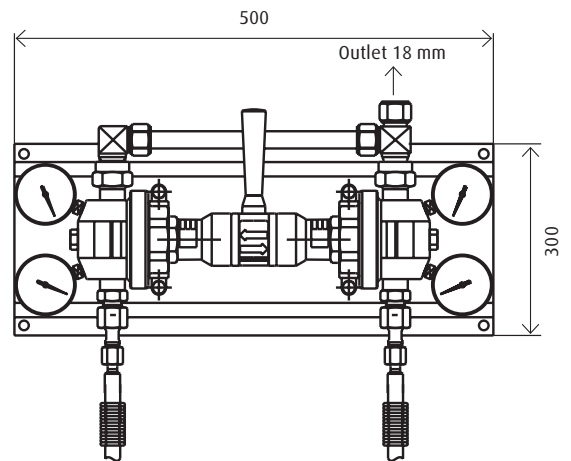

Ordering information

Description	Product no./SAP no.
A35 - N ₂	318435 / 318435
A28 - O ₂	318434 / 318434
A35 - N ₂ - K*	321386 / 321386
A28 - O ₂ - K*	321385 / 321385
High pressure hoses 2 meters O ₂	215191025 / 301946
High pressure hoses 2 meters N ₂	215191030 / 301930

Optional accessories:

- Signs
- Safety valve for distribution network
- Alarm

* With contact gauges.

High pressure hoses ordered separately.

M35/M28.

Single – side Manifold for bundle.

Application

Supply of process gases for laser cutting at high pressure and high flow rates. The standard version is designed for connection of one bundle.

The manifold is equipped with a self – purging valve on the high pressure side. This valve ensure the gas quality after changing the bundle.

The high pressure in the hose demands depressurization when changing bundle.

Specification

- Inlet pressure – 200 bars cylinders.
- Outlet pressure nitrogen 0 – 35 bar.
- Outlet pressure oxygen 0 – 28 bar.
- Purge valves on the inlet pressure side with indicator.
- High pressure hose between purge – valve and bundle.
- Relief valves on regulators with G 3/8" ext RH.
- 18 mm fittings in stainless steel on outlet.
- Inlet threads purge valves W 21,8 x 1/14" ext. RH.
- Temperature range - 30 °C up to + 60 °C.
- Leak rate < 10⁻³ mbar l/s He.
- Mounting plate – Black painted steel.
- Weight regulator unit – 6,5 kg.

Capacity curve – Nitrogen

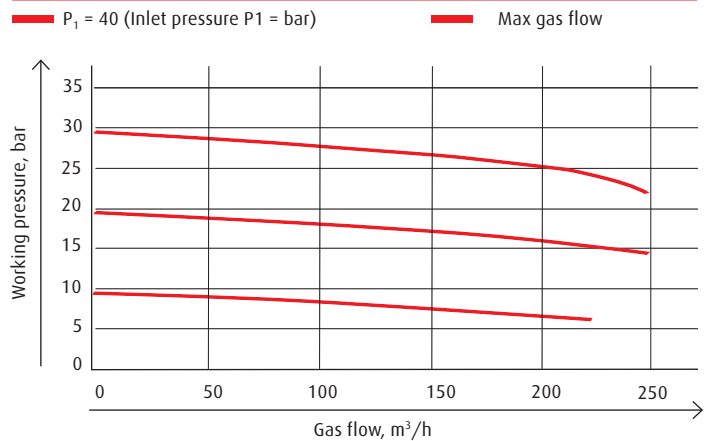

Ordering information

Description	Product no./SAP no.
Valve unit M35 - N ₂	318433 / 318433
Valve unit M28 - O ₂	318432 / 318432
High pressure hoses 2 meters O ₂	215 191 025 / 301946
High pressure hoses 2 meters N ₂	215191030 / 301930

Optional accessories

- Alarm
- Contact gauge
- Signs
- Safety valve for distribution network

* High pressure hose ordered separately.



U35/U28/U16.

Tapping point.

Application

Used for the process gases in laser cutting with need of high pressure and high flow rates.

The second stage pressure regulator after the Manifold.

Specification

- Inlet pressure – 200 bar.
- Outlet pressure nitrogen 0 – 35 bar.
- Outlet pressure oxygen 0 – 28 bar / 0 – 16 bar.
- Inlet 18 mm fittings in stainless steel.
- Outlet 18 mm fittings in stainless steel.
- Relief valves on regulators with G 3/8" ext RH.
- Temperature range - 30 °C up to + 60 °C.
- Leak rate < 10⁻³ mbar l/s He.
- Mounting plate – black painted steel.
- Weight regulator unit – 4 kg.

Capacity curve – Nitrogen

— P₁ = 40 (Inlet pressure P₁ = bar)

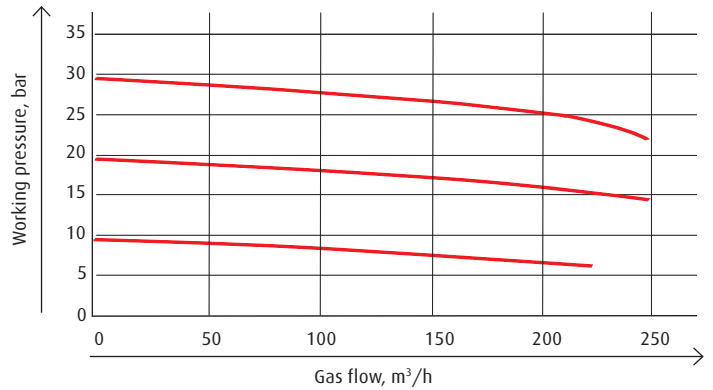

Ordering information

Description	Product no./SAP no.
Tapping point U35 – N ₂	316809 / 316809
Tapping point U28 – O ₂	317322 / 317322
Tapping point U16 – O ₂	321377 / 321377

R35/R28.

Bundle regulator.

Application

Supply of process gases for laser cutting at high pressure and high flow rates. The bundle is intended for use during short periods, for example at start up or when performing maintenance of the central gas supply. A flexible high pressure hose has to be connected on outlet.

Specification

- Inlet pressure - 200 bars cylinder pressure
- Outlet pressure nitrogen 0 – 35 bar
- Outlet pressure oxygen 0 – 28 bar
- 1/2" NPT int. RH on outlet
- Relief valves on regulator with G 3/8" ext RH
- Temperature range - 30 °C up to + 60 °C
- Leak rate < 10-3 mbar l/s He
- Weight regulator unit - 5 kg

Capacity curve - Nitrogen

— $P_1 = 40$ (Inlet pressure $P_1 = \text{bar}$)

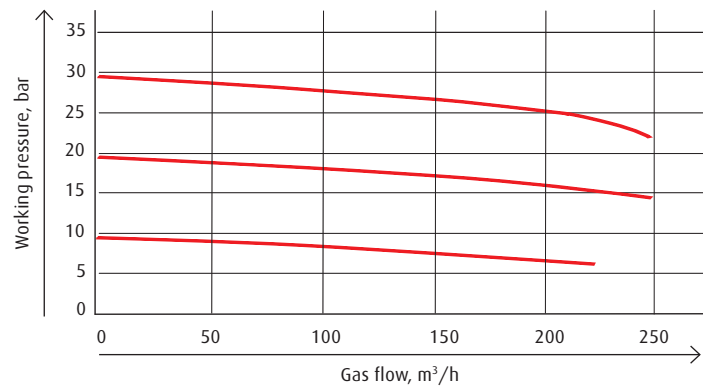

Ordering information

Description	Product no./SAP no.
Valve unit R35 - N ₂	318431 / 318431
Valve unit R28 - O ₂	318430 / 318430

AVK.

Semi-automatic Manifold for cylinders.

Application

Supply of resonator gases with high purity and stable pressure. The manifold may also be used for supply of gases for laser welding.

The manifold is equipped with self-purging valves on the high pressure side. These valves preserve the gas quality after exchanging the cylinder. The manifold ensures continuous gas supply when exchanging cylinders. Two sets of cylinders are connected to the valve unit. One is working as operational side, while the other is held as back-up. Changeover from empty to full cylinder is done automatically. The standard version is designed for one cylinder in operation and one in reserve.

Capacity curve – Nitrogen

— 17 bar (Factory set pressure operational side) — Max gas flow
— 11 bar (Factory set pressure sererve side)

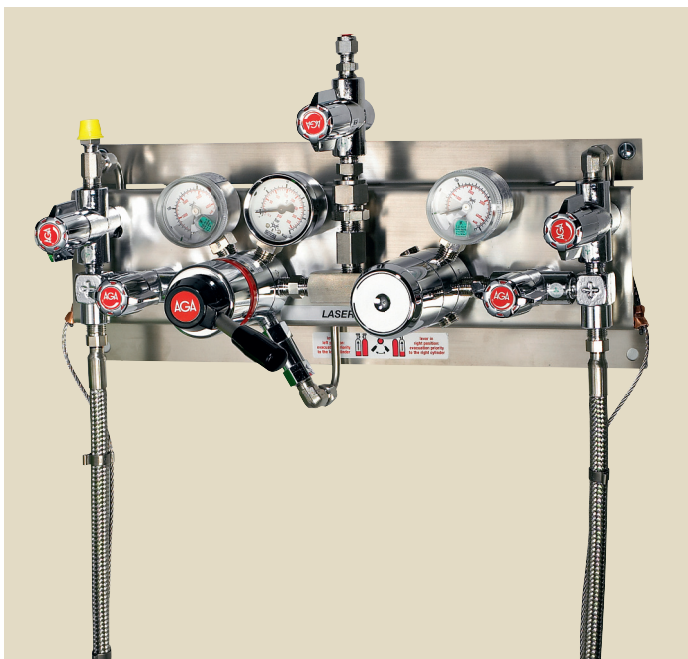
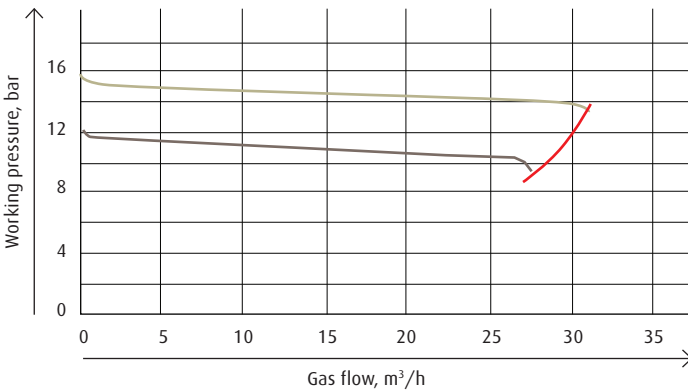

The panel is equipped with contact gauges to enable the alarm function when changing from operational side to reserve side.

Specification

- Inlet pressure – 200 bars cylinders.
- Outlet pressure 14 +/- 3 bar.
- Two contact gauges with junction box - inductive.
- Regulator body in chrome plated brass.
- Diaphragm in Hastelloy®.
- High pressure hose with stainless steel mantle and stainless steel inner hose.
- 6 mm compression fittings on outlet.
- 6 mm compression fittings on outlet from purge valve and relief valve.
- Temperature range - 20 °C up to + 70 °C.
- Leak rate < 10⁻⁶ mbar l/s He.
- Anchor beam for two cylinders.
- Weight regulator unit

Ordering information

Description	Product no./SAP no.
Manifold AVK- He, N ₂ , Lasermix	500088087 / 308944
Manifold AVK- CO ₂	500088184 / 308933

High pressure hoses included.



EV.

Single side Manifold for cylinder.

Application

Supply of resonator gases with high purity and stable pressure. The manifold can also be used for supply of gases during laser welding.

The manifold is equipped with a self-purging valve on the high pressure side. This valve preserves the gas quality after changing the cylinder.

Specification

- Inlet pressure - 200 bars cylinders.
- Outlet pressure 0 – 10,5 bar.
- Regulator body in chrome plated brass.
- Diaphragm in Hastelloy®.
- High pressure hose with stainless steel mantle and stainless steel inner hose.
- 6 mm compression fittings on outlet.
- 6 mm compression fittings on outlet from purge valve and relief valve.
- Temperature range - 20 °C up to + 70 °C.
- Leak rate < 10-6 mbar l/s He.
- Anchor beam for one cylinder.
- Weight regulator unit – 5 kg.

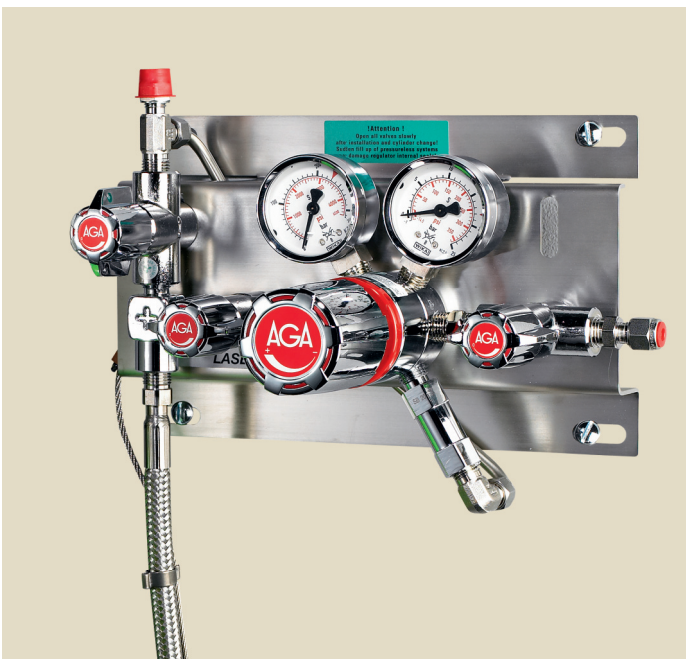

Capacity curve - Nitrogen

— 12 bar - Primærtrykk — Max gas flow

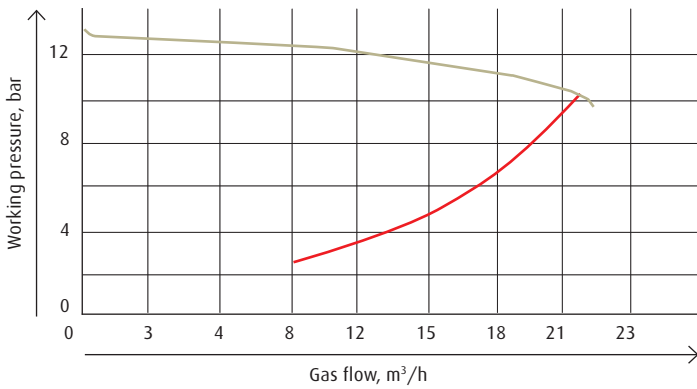

Ordering information

Description	Product no./SAP no.
Manifold EV- He, N ₂ , Lasermix*	500088183 / 308932
Manifold EV- CO ₂ *	500088184 / 308933

* High pressure hose included.

EV.

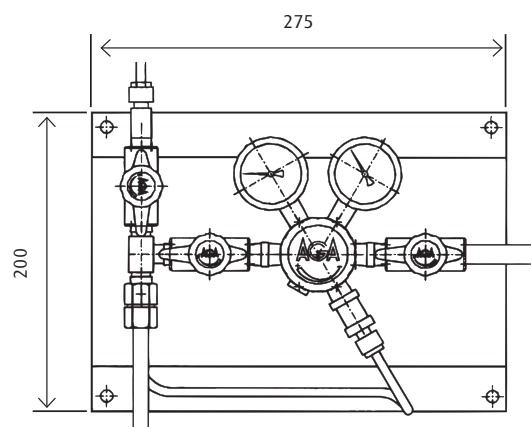
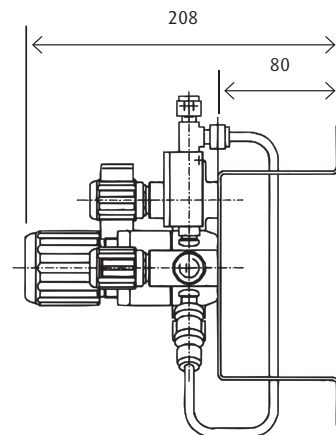

CON.

Single side Manifold for cylinder.

Application

Supply of high purity resonator gases under stable pressure. The manifold can also be used for supply of process gases when laser welding.

The manifold regulator is a two - stage type and the manifold is basic and cost effective solution for gas installations.

The high pressure hose has an incorporated check valve for avoiding air in the system during cylinder exchange.

Specification

- Inlet pressure 200 bars cylinder pressure
- Outlet pressure 0 – 10 bar
- Regulator body in chrome plated brass
- Diaphragm in stainless steel
- High pressure hose with stainless steel mantle and safety wire
- 6 mm compression fittings in stainless steel on outlet
- Wall mounting bracket
- Temperature range - 40 0C – 60 0C
- Leak rate 1×10^{-8} L/S He
- Stainless steel lined high pressure hose with check valve, 1 meters length
- Weight 1,6 kg
- Length x height x depth of manifold regulator = 170x125x220 mm

Ordering information

Description	Product no./SAP no.
Manifold CON - N ₂	321384 / 321384
Manifold CON - O ₂	321383 / 321383
Filter 2 micron	500 025 265 / 311953
Adapter for filter	500 003 087 / 311388

Optional accessories

- Filter 2 micron for in line installation
- Anchor beams
- Signs
- Safety valves for distribution network

High pressure hose included.



Filter + adapter are needed.

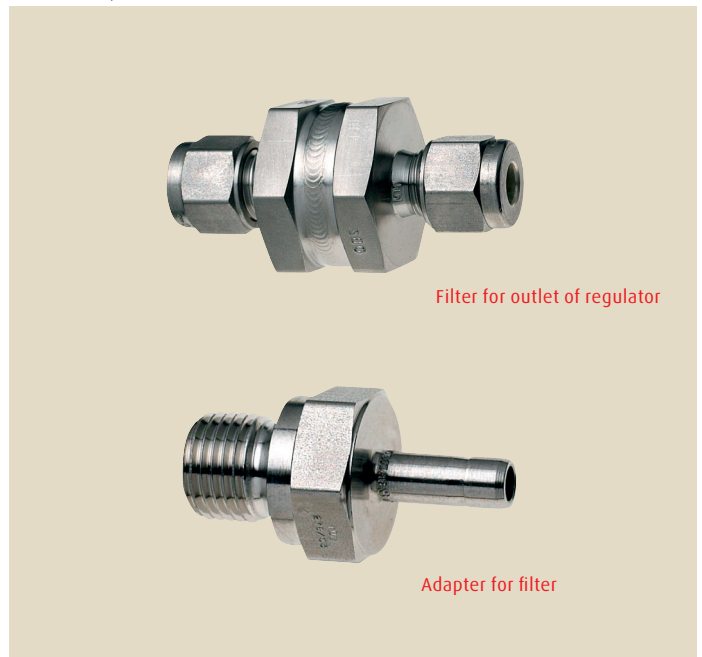

U10.

Tapping point.

Application

Supply of resonator gases with high purity and stable pressure.

The tapping point can also be used for supply of process gases when laser welding. A particle filter is included at the outlet of the tapping point.

Specification

- Inlet pressure – 40 bar.
- Outlet pressure 0 – 10,5 bar.
- Regulator body in chrome plated brass.
- Diaphragm in Hastelloy®
- 6 mm compression fittings in stainless steel on inlet.
- 6 mm compression fittings in stainless steel on outlet.
- Temperature range - 20 °C up to + 70 °C.
- Leak rate < 10⁻⁶ mbar l/s He.
- 2 µm particle filter.
- Capacity – max. 11 Nm³/ H, N₂.
- Weight regulator unit – 1,5 kg.

Ordering information

Description

Tapping point He, N₂, CO₂, Lasermix

Product no./SAP no.

500084464 / 308957



R2/R2V.

Cylinder regulator.

Application

A two stage pressure regulator designed for supply of high purity resonator gases with stable pressure.

One model is equipped with purge valve on the high pressure side. This valve preserves the gas quality after exchanging the cylinder.

The cylinder regulator is delivered with a particle filter at the outlet.

Specification

- Inlet pressure – 200 bars cylinder pressure.
- Outlet pressure 0 – 10,5 bar.
- Two – stage regulator.
- Regulator body in chrome plated brass.
- Diaphragm in Hastelloy®.
- 6 mm compression fittings on outlet.
- Temperature range - 20 °C up to + 70 °C.
- Leak rate < 10⁻⁶ mbar l/s He.
- Capacity 10 Nm³/ H, N₂.
- Weight regulator unit – 2 kg.



Capacity curve - Nitrogen

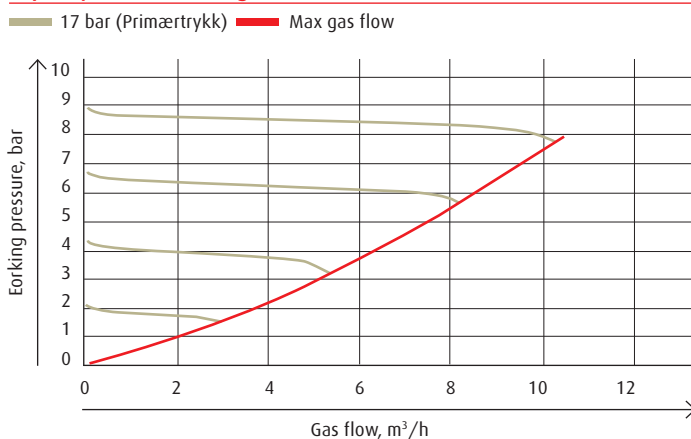

R2/R2V.

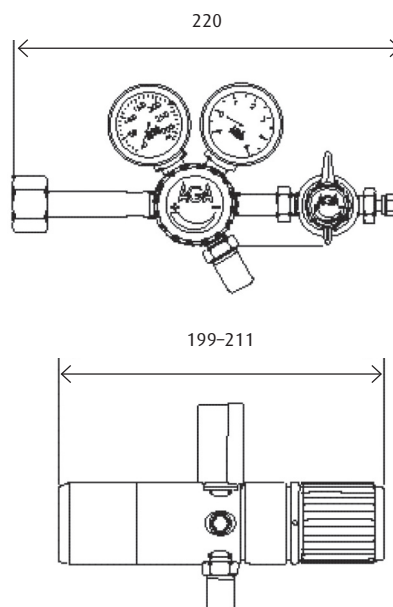

Ordering information

Description	Product no./SAP no.
Manifold R2 - He, N ₂ , Lasermix	500084715 / 308971
Manifold R2- CO ₂	500084716 / 308972
Manifold R2V - He, N ₂ , Lasermix	500084717 / 308973
Manifold R2V- CO ₂	500084718 / 308974

PURE.

Filter.

Application

A line filter for process gases when laser cutting in order to avoid operational disturbances in the gas supply system.

Specification

- Max inlet pressure – 200 bar
- Brass housing
- 10 – 25 µm cartridge in sinter bronze
- Easy changeable cartridge
- Capacity = 8nm3 / h x working pressure (bar)
- Weight 1 kg
- G ½" ext. inlet and outlet
- 18 mm compression fittings in stainless steel on inlet and outlet included
- Suitable for nitrogen and oxygen

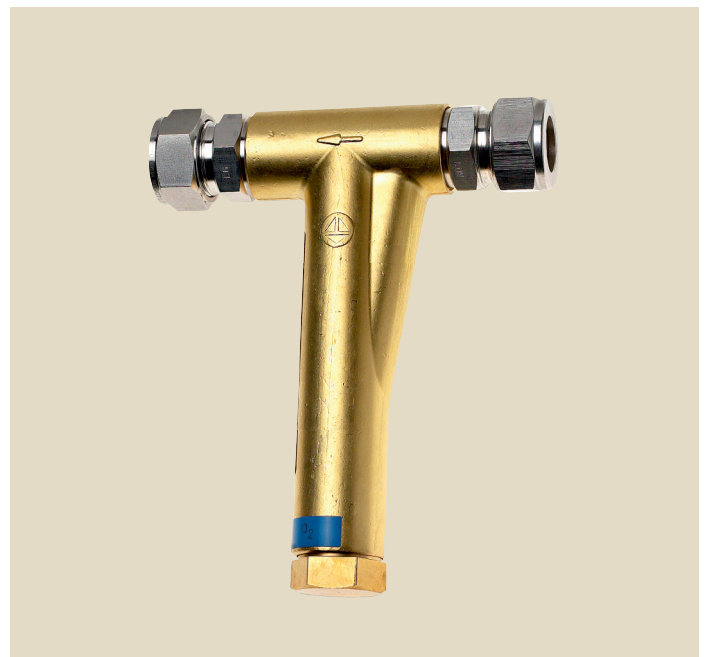

Ordering information

Description
Filter PURE

Product no./SAP no.
320526 / 320526

Safety valve.

Application

The safety valve protects piping and components in the gas supply system against abnormal pressure increase. The safety valve should be chosen for the specific application.

The safety valve is installed at the low pressure side and after the manifold.

A ventilation pipe should be installed on the outlet.

According to the Pressure Equipment Directive 97/23 / EC safety valves should be CE marked.

If there is a specific demand for max inlet pressure into the laser machine, a separate safety valve should be installed after the tapping point.

Technical specification

- 20 bar set pressure for resonator gases.
- Brass
- CE market
- G ½" thread on inlet
- M16 thread on outlet
- Adapter on outlet for 1 /2" NPT internal thread (extra)
- Capacity 375 Nm3 air, (20 °C)
- Weight 0,25 kg
- Height 90 mm
- Temperature limit -20 °C



Ordering information

Description	Product no./SAP no.
Safety valve 20 bar	318819 / 318819
Adapter outlet connection ½" NPT internal threads	318842 / 318842

Safety valve.

Application

The safety valve protects piping and components in the gas supply system against abnormal pressure increase. The safety valve should be chosen for the specific application.

The safety valve is installed at the low pressure side and after the manifold.

A ventilation pipe should be installed on the outlet.

According to the Pressure Equipment Directive 97/23 / EC safety valves should be CE marked.

If there is a specific demand for max inlet pressure into the laser machine, a separate safety valve should be installed after the tapping point.

Technical specification

- 65 bar set pressure for process gas.
- Blue painted stainless steel body
- CE market
- G 3/4" external thread on inlet
- G 1/2 " internal thread on outlet
- Certified capacity 1579 Nm3 air, (20 °C)
- Weight 1,6 kg
- Height 220 mm
- Temperature limit -10 °C

Ordering information

Description

Safety valve 65 bar

Product no./SAP no.

323560 / 323560



Ball valve.

Application

Used as a main shut - off -valve or a service valve for the process gases at the low pressure side of the gas system. Normally the valve is installed directly after the supply source or in front of the tapping point regulator.

Technical specification

- Ball valve size DN15 and DN25
- Max inlet pressure 64 bar
- Body and stem in stainless steel
- Sealing in PTFE
- Version with welded nipples in stainless steel
- Version with 18mm compression fittings in stainless steel pressure tested
- Min. temperature - 60 °C
- Weight approximately 1,7 kg for DN 15 version
- Weight approximately 3,9 kg for DN 25 version
- Cleaned for oxygen use

Ordering information

Description	Product no./SAP no.
Ball valve DN 15, 18 mm fittings	323612 / 323612
Ball valve DN 15, welded nipple 21,3 x 2,0 mm	323606 / 323606
Ball valve DN 25, welded nipple 33,7 x 2,6 mm	323605 / 323605



Getting ahead through innovation.

With its innovative concepts, AGA is playing a pioneering role in the global market. As a technology leader, our task is to constantly raise the bar. Traditionally driven by entrepreneurship, we are working steadily on new high-quality products and innovative processes.

AGA offers more. We create added value, clearly discernible competitive advantages and greater profitability. Each concept is tailored specifically to meet our customers' requirements – offering standardized as well as customised solutions. This applies to all industries and all companies regardless of their size.

AGA – ideas become solutions

Sweden

AGA Gas AB
www.aga.se

Norway

AGA AS
www.aga.no

Iceland

ISAGA ehf
www.aga.is

Latvia

AGA SIA
www.aga.lv

Finland

Oy AGA Ab
www.aga.fi

Denmark

AGA A/S
www.aga.dk

Estonia

AS Eesti AGA
www.aga.ee

Lithuania

AGA UAB
www.aga.lt