



## SOLVOX<sup>®</sup> mobile – oxygen for water. Flexible and simple solution for capacity increase in small- to medium-sized industrial wastewater treatment plants.



### Boosting your plant capacity

Linde's SOLVOX<sup>®</sup> product line has been developed to meet aeration and mixing needs in wastewater treatment plants. The SOLVOX mobile is a flexible solution suitable for all industrial wastewater treatment plants using aeration processes. It can be used to bridge seasonal and production peaks or as a backup solution during maintenance. Its modular concept allows for flexible capacity management and it can be easily stored and installed again when needed. A single unit can oxygenate and mix around 150 to 200 m<sup>3</sup> [39,000 to 53,000 US gallons] of wastewater aeration basin volume.

### Benefits at a glance

- Portable, lightweight submerged jet dissolver
- Flexible installation to fit any shape of basin: floating or fixed, horizontal or vertical
- Wet installation: no need to drain the tank or halt operation
- Low maintenance and operation costs
- Allows for rapid response to temporary peak loads and maintenance of main aeration equipment

### Installation

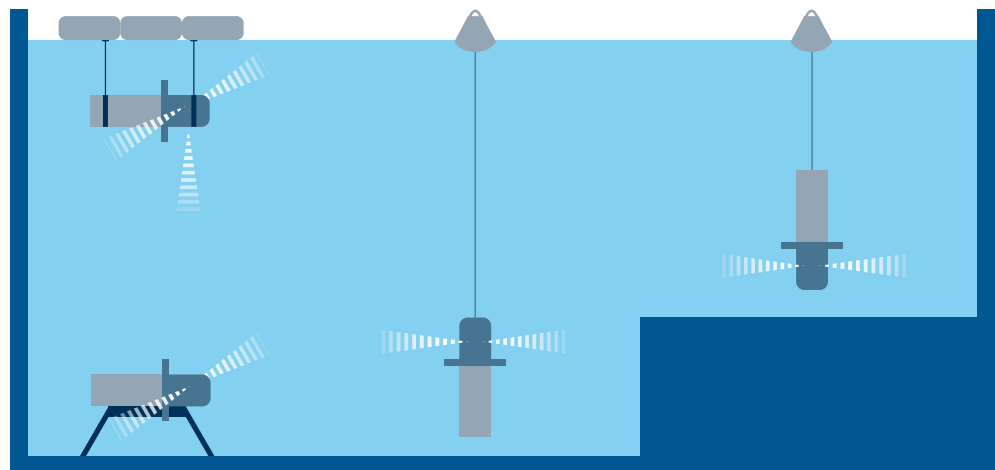

Flexible installation. Submerged venturi mixer for better mixing power and improved dissolved oxygen distribution. Nozzles can be blocked to enable horizontal mounting.

### Who can benefit from SOLVOX mobile

- Ideal for small- and medium-sized industrial plants, both with temporary and semi-permanent aeration needs
- Operators who face variable loading or seasonal demand
- Plants with moderate mixing demand that need additional mixing
- Basins with water depth ranging from 3 m to 15 m (10 to 49 ft)

### Technical characteristics

SOLVOX mobile	Metric system	Imperial system
Capacity O <sub>2</sub> /h	10 to 25 kg	22 to 55 lbs
Power rating P1	7,5 kW	10 hp
Power supply	380-400 V / 50 Hz (EU version)	480 V / 60 Hz (US version)
Weight	105 kg	232 lbs
Cable	20 m	66 ft
Head	1,5 barg	218 psi
Total height	1410 mm	4,6 ft
Pump type (IP68)	Centrifugal – radial	Centrifugal – radial
Water temperature max.	45 °C	113 °F
Pump flow	50-60 m <sup>3</sup> /h	13200-15850 gal/h
Minimum immersion	3 m	10 ft
Maximum immersion <sup>1</sup>	15 m	49 ft
Solids diameter	<10 mm	<0.39 in

<sup>1</sup> Allows for 5m (16ft) of cable out of the water.

### External features and dimensions

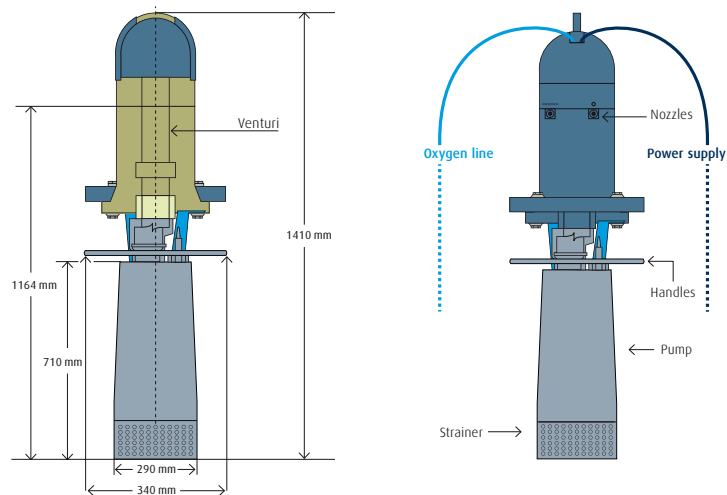

- Four jet nozzles for effective mixing
- High-density polyethylene body (HDPE)
- Patented SOLVOX low-pressure-drop venturi
- Stainless steel pump body
- Low noise level
- No aerosol, noise or foam